

Aerocom's Three Phase Blower

SD4-8

SD4—8 Specifications:

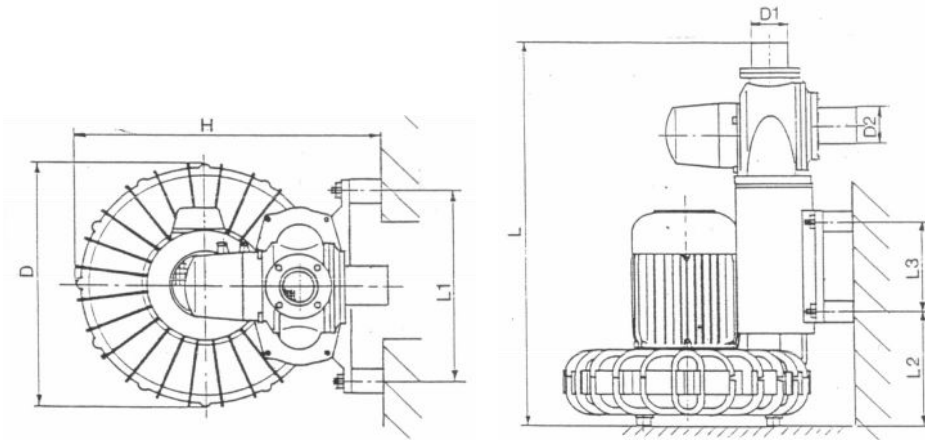

	L	D	H	D1	D2	L1	L2	L3
SD4	21.93	14.09	16.73	2.17	2.17	8.66	6.73	4.72
SD6	26.50	15.59	18.58	2.56	2.56	12.20	7.95	6.30
SD7	33.27	18.11	21.26	3.15	3.15	14.37	8.11	10.24
SD8	34.25	19.69	22.91	3.15	3.15	14.37	8.94	10.24

*Dimensions are in Inches

Uses:

The three-phase-blower switches from pressure to vacuum in a split second through the three position valve. As soon as all pending sending processes are finished, the three-phase-blower will automatically shutoff. Noise should not be an issue as the blower is housed in noise-reducing cast aluminum.

Installation:

The three phase blower is typically installed on the floor, in the ceiling or on the wall in close proximity to the main system controls and/or the master station.

aerocom

Aerocom's Three Phase Blower

SD4-8

SD4—8 Technical Data:

Efficiency Class: IE2

Enclosure: IP 54

Frequency: 60 Hz

Allowable Ambient Temperature: -20°C to +60°C



Blower Housing and open/closed impellers made of cast aluminum, Direct motor, IE2-compliant, Integrated silencer, Compact construction, Corrosion-resistant.

DATA	SD4	SD6	SD7	SD8
Horse Power (HP)	2.14	4.15	4.90	6.5
Voltage (60Hz)	208	208	208	208
Amps	6.6	7.0	8.0	10.4
RPMs	3400	3440	3500	3525
Power Factor kW/kVA	.82	.83	.82	.85
Air Volume m ³ /min	3.4	5.4	8.0	11.0
Pressure Max. in mbar	225	230	270	280
Initial Start up Amps	7.6	13.9	13.9	17.7
RUN-UP Time in Seconds	4	4	4	4
Noise Level dB A*	73	79	78	82
Heat Emission kW/h	.25	.55	.6	1.2
Cooling Air f. motor m ³ /h	105	150	210	440
Weight with Switching Valve in pounds	59.5	92.6	143.3	187.39
PART NUMBER	311-741419	311-741428	311-741433	311-741408

Features:

Side Channel Airflow

Energy Efficient IE2/NEMA Motor

Conformant to IEC6003430

Air Volume Dissipates Heat Generated

Reduces Operating Energy and Costs

Long-lasting Service Life

The Aerocom logo, featuring the word "aerocom" in a bold, red, lowercase sans-serif font.